



Length	37.7 in (958 mm)
Width	26.77 in (680 mm)
Height	1.34 in (34 mm)
Frame	Aluminum
Weight	16.11 lb (7.6 kg)

Sunmodule® SW 80 poly RNA

World class quality

SolarWorld produces the best products with the highest quality, manufactured according to German and US quality standards in fully-automated ISO 9001 and 14001 certified factories.

Efficell® – Made in Germany

High-efficiency SolarWorld poly cells are made in Germany for maximum performance and quality.

Independently proven to produce more energy

Independent testing carried out by the Photon trade magazine in 2008 and 2009 showed that SolarWorld modules produced up to 12% more kilowatt-hours than other major brands.

An experienced industry leader

With over 30 years of experience in off-grid solar applications – SolarWorld delivers top products and technical experience at the highest levels. Our modules are installed in over 100,000 Telecom/Industrial systems worldwide. Nobody else comes close.



Sunmodule®

SW 80 poly RNA

PERFORMANCE UNDER STANDARD TEST CONDITIONS (STC)*

SW 80		
Maximum power	P_{max}	80 Wp
Open circuit voltage	U_{oc}	21.9 V
Maximum power point voltage	U_{mpp}	17.9 V
Short circuit current	I_{sc}	4.78 A
Maximum power point current	I_{mpp}	4.49 A

*STC: 1000W/m², 25°C, AM 1.5

PERFORMANCE AT 800 W/m², NOCT, AM 1.5

SW 80		
Maximum power	P_{max}	58.0 Wp
Open circuit voltage	U_{oc}	19.7 V
Maximum power point voltage	U_{mpp}	16.1 V
Short circuit current	I_{sc}	3.85 A
Maximum power point current	I_{mpp}	3.59 A

Minor reduction in efficiency under partial load conditions at 25°C: at 200W/m², 95% (+/-3%) of the STC efficiency (1000 W/m²) is achieved.

COMPONENT MATERIALS

Cells per module	36
Cell type	Poly crystalline
Cell dimensions	3.7 in x 6.14 in (94 mm x 156 mm)
Front	tempered glass (EN 12150)

SYSTEM INTEGRATION PARAMETERS

Maximum system voltage SC II	1000 V
Maximum reverse current	12 A
Number of bypass diodes	2

THERMAL CHARACTERISTICS

NOCT	46 °C
TC I_{sc}	0.034 %/K
TC U_{oc}	-0.34 %/K
TC P_{mpp}	-0.48 %/K

ADDITIONAL DATA

Power tolerance	-5 / +10 %
Junction box	IP65
Maximum outer cable diameter	0.27 in (6.9 mm)
Maximum wire cross section	0.006 in ² (4 mm ²)

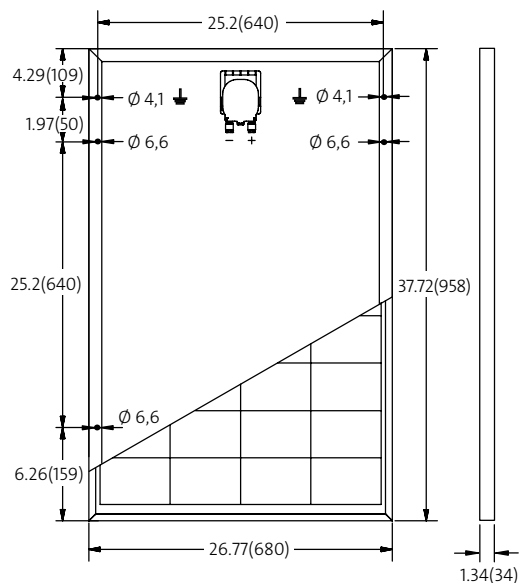

· Qualified, IEC 61215
· Periodic Inspection



SolarWorld AG reserves the right to make specification changes without notice. This data sheet complies with the requirements of EN 50380.